

**Colombo Municipal Council**  
**FIRE SERVICE DEPARTMENT**  
**Mandatory Structural Fire Protection and Access Requirements to be Included in Proposed Building Plans**

Guideline for Building Designers, Architects, Town Planners and Developers.

**(This Guideline shall be read in conjunction with the CIDA regulations as per CID Act no 33 of 2014)**

**A. Structural and Access Requirement**

**1. Protected Stairway:**

- a) The stairway shall be separated from the remainder of the building by 60 min./ 90 min./ 120 min. fire resisting construction and 30 / 60 minute fire doors to form a stairway enclosure.
- b) All doors shall open in the direction of escape.
- c) Scissor type protected stairways are not acceptable for super-high rise buildings.

**2. Alternative Means of Escape:**

- a) Alternative protected stairway not less than 1 m. wide shall be provided up to the highest floor level, access from all floors.
- b) Scissor type protected stairways are not acceptable as alternative means of escape for super-high rise buildings.

**3. Fire Fighting Shaft Requirement:**

- a) Floor area up to 900 m<sup>2</sup> - 01 No and up to 2000 m<sup>2</sup>- 02 Nos.
- b) Construction - 02 hour fire rated.
- c) Fire fighting / escape stairway width - 1050 mm wide
- d) Fire fighting lobby - not less than 06 m<sup>2</sup>
- e) Firefighting /evacuation lift - Dimensions; 2100 mm x 1100 mm

**4. Compartmentation:**

- a) Below Ground level - No compartment to comprise more than one storey.
- b) Ground level to 30 m. in height - No compartment to comprise more than 3 storeys.
- c) More than 30 m. from ground level - No compartment to comprise 01 storey.

**5. Fire Command Centre:**

- a) Construction - 02 hour fire rated.
- b) Location - Fire vehicle access level
- c) Floor area - 10 m<sup>2</sup>

**6. Refuge Floor and Holding Area:**

Designation of refuge floor at an interval of every 10<sup>th</sup> floor from the top most floor of the building.

**Holding Area:**

- a) Construction - 02 hour fire rated, adjacent to firefighting shaft.
- b) Floor area - 0.5m<sup>2</sup> of the 50% of total occupants of 10 floors above including refuge floor based on occupancy factor.

**7. Provision for External Access:**

- a) Access: Minimum road access - 4.5 m and head room - 4.5, turning circle between kerbs - 24 m. for 40 ton high reach appliance.
- b) Hard standing: Dimension - 7 m x 15 m., within 2 m. to 10 m. from the building.
- c) Habitable floor less than 18 m -clear working space 4 m x 4 m wide along the side of the building.
- d) Dead-end access –maximum 20 m, if exceed turning facilities to be provided.

## **B. Height Category of Buildings:**

**(Ground level to floor level of top most habitable floor)**

01	Up to 18 m & Total floor area less than 800 m <sup>2</sup>	Low rise - Category 1
02	Up to 18 m & Total floor area 800 m <sup>2</sup> and above	Low rise - Category 2
03	Between 18 m. up to 30 m.	Medium rise
04	Between 30 m. up to 60 m.	High rise
05	60 m. and above	Super high rise

## **C. Requirements as per Occupancy**

### **1. Block of Residential Apartments**

#### **1.1 Low rise - Category 2:**

- a) Protected stairway (60 min. fire rated)
- b) If a smoke free approach with 3 m<sup>2</sup> lobby is provided, single staircase may be permitted.

#### **1.2 Medium rise :**

- a) Protected stairway (90 min. fire rated)
- b) Compartmentation
- c) Provision for external access
- d) If a smoke free approach with 3 m<sup>2</sup> lobby is provided, single staircase may be permitted.

#### **1.3 High rise**

- a) Protected stairway (120 min. fire rated)
- b) Compartmentation
- c) Firefighting shaft
- d) Fire Command Centre
- e) Provision for external access
- f) Single staircase may be permitted only if;
  - i. a smoke free approach with 3 m<sup>2</sup> lobby is provided
  - ii. number of apartments in each floor is not more than 04
  - iii. the travel distance to the staircase is not exceeding 15 m from most remote exit door

#### **1.4 Super high rise:**

- a) Protected stairway (120 min. fire rated)
- b) Compartmentation
- c) Firefighting shaft
- d) Fire Command Centre
- e) Refuge floor & holding area
- f) Provision for external access
- g) Single staircase not permitted

### **2. Buildings other than Residential Apartment and Car park**

#### **2.1 Low rise - Category 1:**

- a) Protected stairway (60 min. fire rated)

#### **2.2 Low rise - Category 2:**

- a) Protected stairway (60 min. fire rated)
- b) Alternative means of escape (Spiral stairway accepted up 10 m.)

### 2.3 Medium rise:

- a) Protected stairway (90 min. fire rated)
- b) Compartmentation
- c) Alternative means of escape
- d) Provision for external access

### 2.4 High rise:

- a) Protected stairway (120 min. fire rated)
- b) Alternative means of escape
- c) Compartmentation
- d) Firefighting shaft
- e) Fire Command Centre
- f) Provision for external access

### 2.5 Super high rise:

- a) Protected stairway (120 min. fire rated)
- b) Alternative means of escape
- c) Compartmentation
- d) Firefighting shaft
- e) Fire Command Centre
- f) Refuge floor & holding area
- g) Provision for external access

## 3. Car Parks (other than Purpose Group 8b)

### 3.1 Low rise - Category 2:

- a) Protected stairway (60 min. fire rated)
- b) Alternative means of escape

### 3.2 Medium rise - Category:

- a) Protected stairway (90 min. fire rated)
- b) Provision for external access
- c) Alternative means of escape

### 3.3 High rise:

- a) Protected stairway (120 min. fire rated)
- b) Firefighting shaft
- c) Fire Command Centre
- d) Provision for external access
- e) Alternative means of escape

\* Compartmentation:

Zonal compartmentation is required for common car parks of multi towered complex buildings.

### Firefighting Shafts

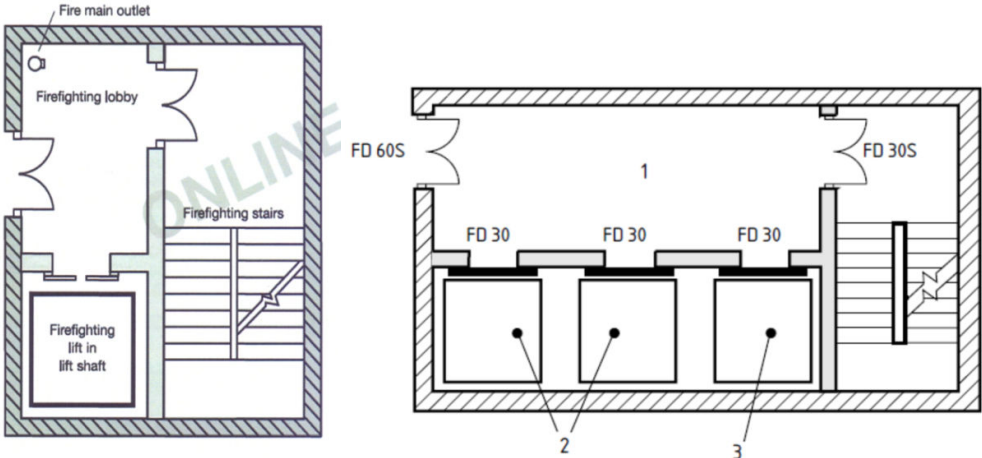

- 1. Fire fighting lobby ( 6 m<sup>2</sup>)
- 2. Passenger lift
- 3. Fire fighting lift

### Protected Stairway

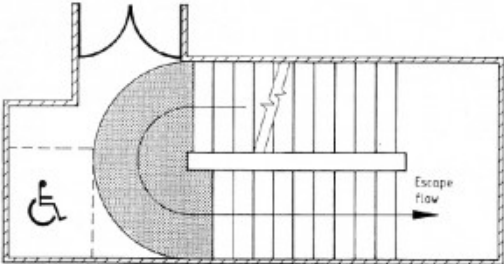

### Alternative Means of Escape

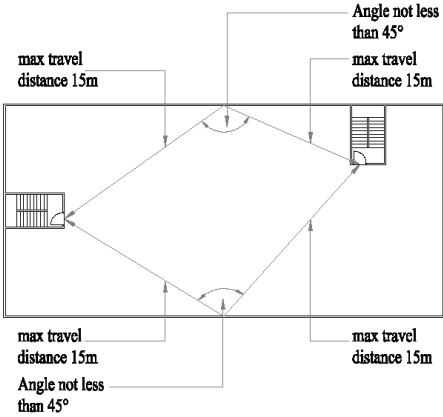

### Hard Standing

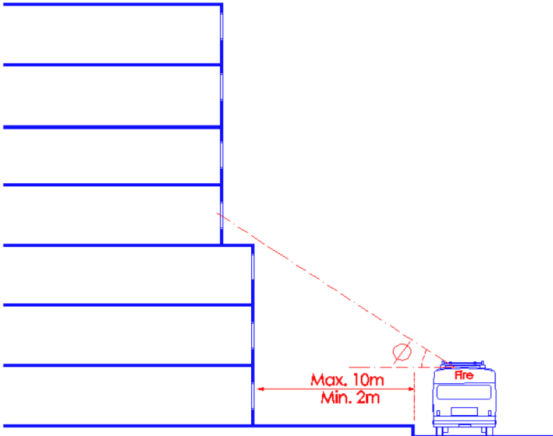

### Fire Vehicle Access

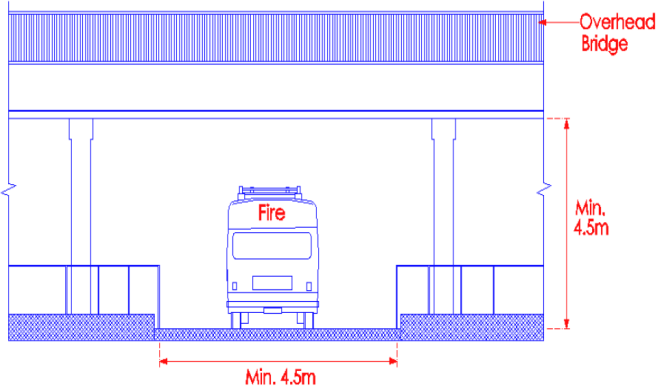

## Turning Circle for High Reach Appliances

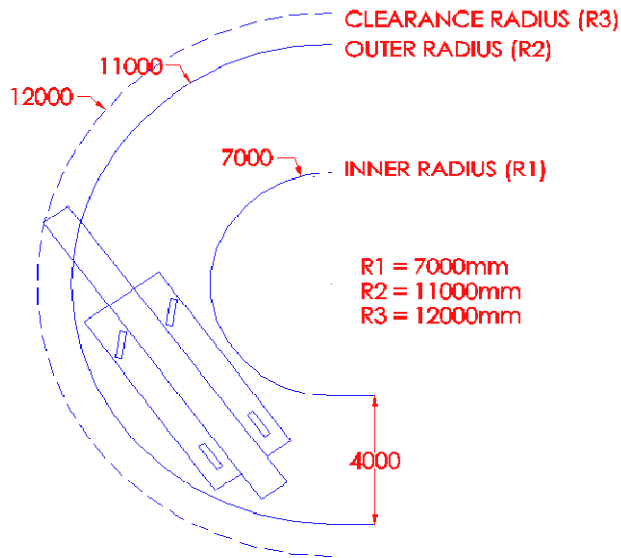

It is compulsory to incorporate the above structural requirements to proposed building plans according to the height category and nature of occupancy of proposed buildings.

The plans drawn without necessary structural requirements will not be accepted for preliminary clearance.

**Chief Fire Officer**  
**Fire Service Department**

01 September 2017